

Pitch diameter

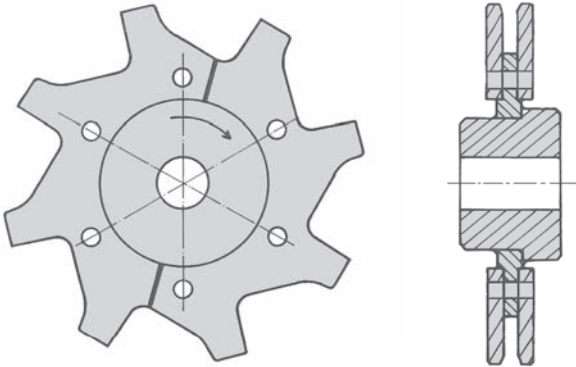

z/p	76,2	101,6	102	135	142	150	160	200	250	260
6		203	204	270	284	300	320	400	500	520
7	176	234	235	311	327	346	369	461	576	599
8	199	265	267	353	371	392	418	523	653	679
9	223	297	298	395	415	439	468	585	731	760
10	247	329	330	437	460	485	518	647	809	841
11	271	361	362	479	504	533	568	710	888	923
12	294	393	394	522	549	580	618	773	966	1005
13	318	425	426	564	593	627	669	836	1045	1087
14	342	457	458	607	638	674	719	899	1124	1168
15	366	489	491	649	683	721	769	962	1202	1250
16	391	521	523	692	728	769	820	1025	1281	1333
17	415	553	555	735	773	816	871	1088	1360	1415
18	439	585	587	777	818	864	921	1152	1440	1497
19	463	617	620	820	863	911	972	1215	1519	1580
20	487	649	652	863	908	959	1023	1279	1598	1662
21	511	682	684	906	953	1006	1073	1342	1677	1744
22	535	714	717	949	998	1054	1124	1405	1757	1827

p = pitch
z = number of teeth

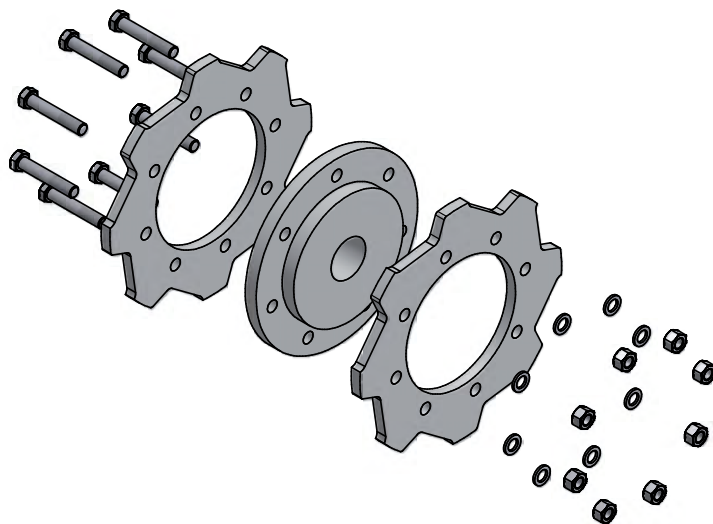

Drive Sprocket for Drop Forged Scraper Chain

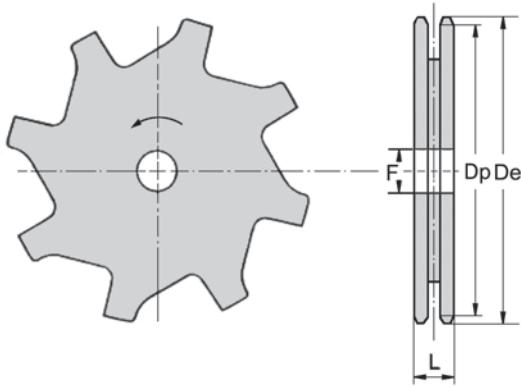

Chain	Number of teeth	Dp mm	De mm	F mm	L mm
66102	6	203,20	216	25	34
	8	265,50	275		
	10	328,80	340		
	12	392,60	405		
66102/R	6	203,20	216	25	34
	8	265,50	275		
	10	328,80	340		
	12	392,60	405		
69290	6	284,00	304	25	34
	8	371,06	390		
	10	459,52	470		
	12	548,70	570		
69218	6	284,00	304	40	50
	8	371,06	390		
	10	459,52	470		
	12	548,70	570		
69222	6	284,00	304	40	60
	8	371,06	390		
	10	459,52	470		
	12	548,70	570		
69226	6	284,00	304	50	70
	8	371,06	390		
	10	459,52	470		
	12	548,70	570		
70090	6	300,00	314	25	34
	8	391,65	406		
	10	485,55	500		
70014	6	300,00	314	25	50
	8	391,65	406		
	10	485,55	500		
71025	8	418,09	445	50	60
	10	517,77	545		
77025	8	522,40	565	70	80
	10	647,40	690		
75040	8	653,27	690	70	80
76040	8	679,40	710	70	80

These wheels are available with removable toothed segments in hardened carbon-steel or hardened alloy steel.