

Motorcycle Racing Chain - O-ring Type

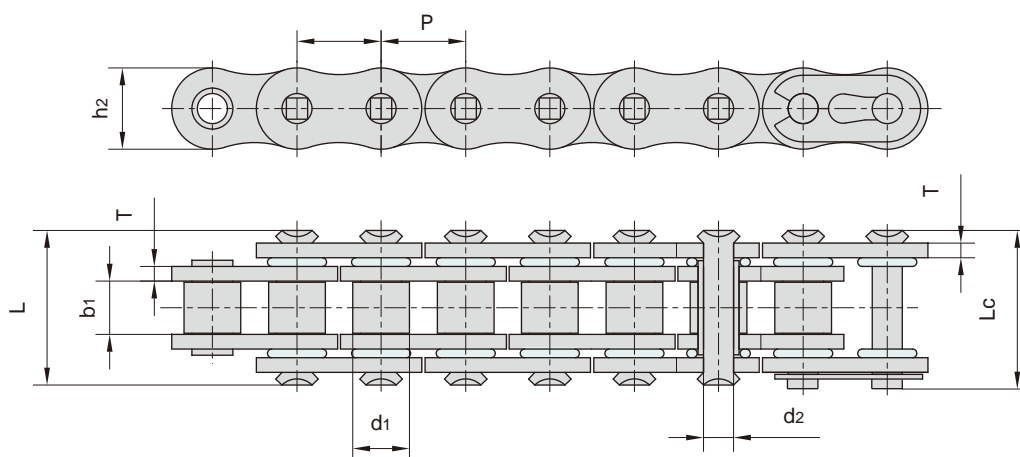

■ HD Non-O-ring chains are designed for off-road applications. They perform perfect against rugged terrain riding. With upgraded alloy steel parts, subject to exclusive heat-treatment process. Outer plate colors available: golden, silver.



chain no.	Pitch	Roller diameter	Width between inner plates	Pin diameter	Pin length		Inner plate depth	Plate thickness	Ultimate tensile strength	Average tensile strength	Weight per meter
	P	d1 max	b1 min	d2 max	L max	Lc max	h2 max	T max	Q min.	Q ₀	q
	mm	mm	mm	mm	mm	mm	mm	mm	kN/LB	kN	kg/m
420 OR	12.700	7.77	6.35	3.96	16.65	17.95	12.00	1.50	16.0/3599	17.00	0.62
420H OR	12.700	7.77	6.35	3.96	18.80	20.10	12.00	1.80	16.0/3599	17.00	0.75
428H OR	12.700	8.51	7.94	4.45	21.70	22.70	12.30	2.20	22.0/4946	23.00	0.85
520 OR	15.875	10.16	6.35	5.24	20.80	21.90	15.09	2.03	30.4/6840	31.80	0.94
520H OR	15.875	10.16	6.35	5.24	21.52	22.92	15.09	2.40	34/6840	35.00	1.00
525 OR	15.875	10.16	7.94	5.24	22.50	23.90	15.09	2.03	30.4/6840	31.80	0.98
525H OR	15.875	10.16	7.94	5.24	23.80	25.20	15.09	2.40	34.0/7650	35.00	1.12
530 OR	15.875	10.16	9.50	5.24	23.80	25.20	15.09	2.03	30.4/6840	31.80	1.11
530H OR	15.875	10.16	9.60	5.24	25.40	26.80	15.09	2.40	34/7650	35.00	1.20

■ O-ring chain provide permanent lubrication sealing between pin and bush, thus ensuring longer lifetime and minimum maintenance.

With solid bushing, high quality pin material, 4-side riveting both in standard and reinforced (H) O-ring chains. Outer plate colors available: golden, silver. Painted plate colors available: red, yellow, orange, green, blue.